

INFECTION CONTROL WASH BASIN



medi-flo

The logo for 'medi-flo' consists of the brand name in a bold, sans-serif font. The 'medi-' part is black, and the '-flo' part is blue. Below the text is a stylized graphic element: a blue wave-like shape that transitions into three black circles of varying sizes, connected by thin lines, suggesting a network or a flow.

*Make
it
Wonderful*

FRANKE

PREFACE

Electrochemical water disinfection a safe and effective way to help sanitize the sink and help keep the drain and trap free of CPOs & other pathogens. During use and at periodic intervals, an electrolytic process occurs which reconstitutes the water molecules into mixed oxidants which are hostile to bacteria. No chemicals or consumables are added or used during this process. During use this electrolyzed water will flood the drain and aid in cleaning and disinfection. Please note this process is intended to augment (not replace) current cleaning or infection control protocols at the facility.

Other features include a standard 20 second lathering timer and a post-wash cycle of 3 seconds of water runtime which helps wash all residue down into the sink drain. A daily purge cycle is also standard to help prevent stagnant water in the lines, maintain outlet temperatures and ensure continuous waste treatment. Medi-flo is designed for hand washing only and is not to be used as a drinking source, to wash instruments or bedpans etc. Recommended for areas with normal water conductivity above 75 TDS (total dissolved solids). If unaware of your local water conductivity, please contact customer service and this can easily be determined for you before you install the product.

Medi-flo is recommended to be installed with a thermostatic mixing valve and set to a temperature of 27-38C. (Optional accessory MEDI-MIX is available from Franke.) Franke Medi-flo sink is designed to install on provided wall hanger brackets. If mounting on a wall that cannot support the load, we recommend the use of our FRANKE in-wall carrier IWC2104.

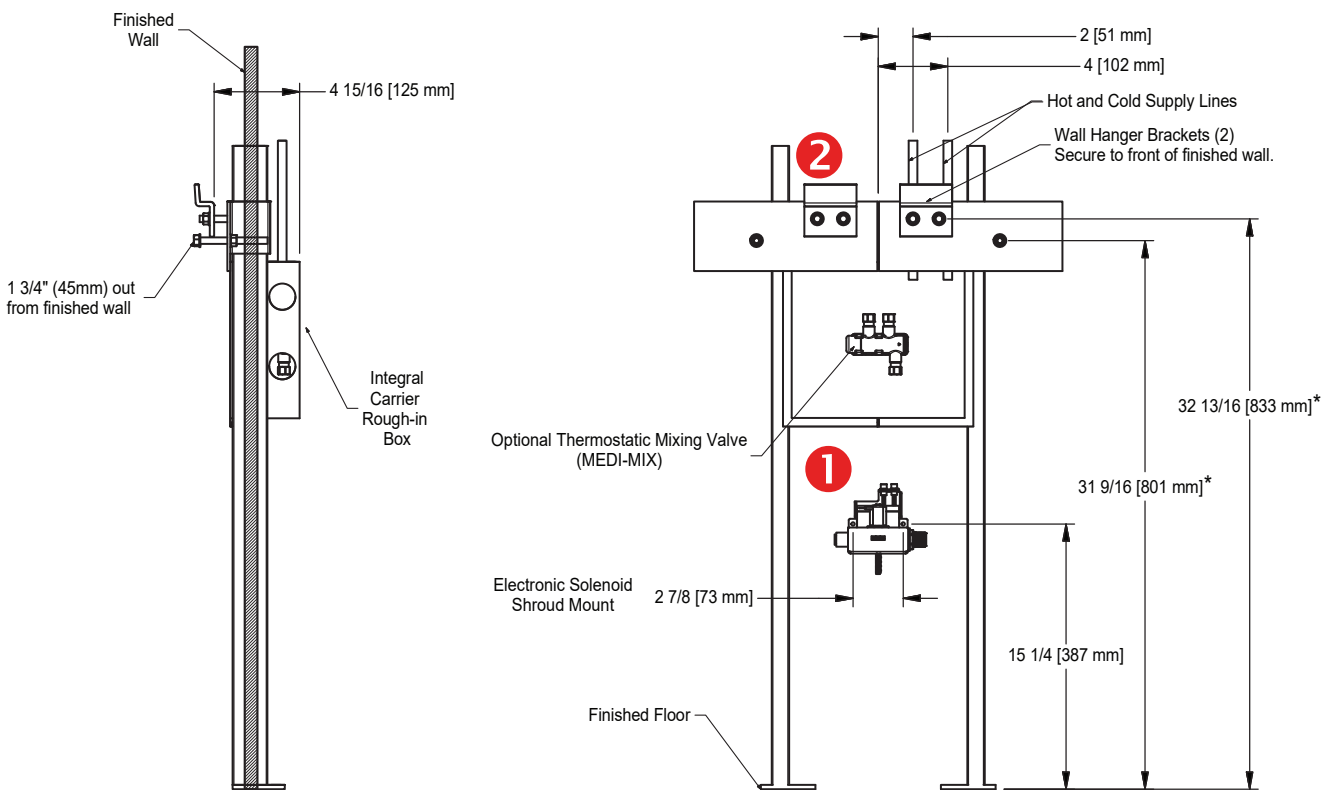

- Notes:
 1. * Yields a finished rim height of 33" (832mm)
 2. Recommended carrier FRANKE IWC2104

2

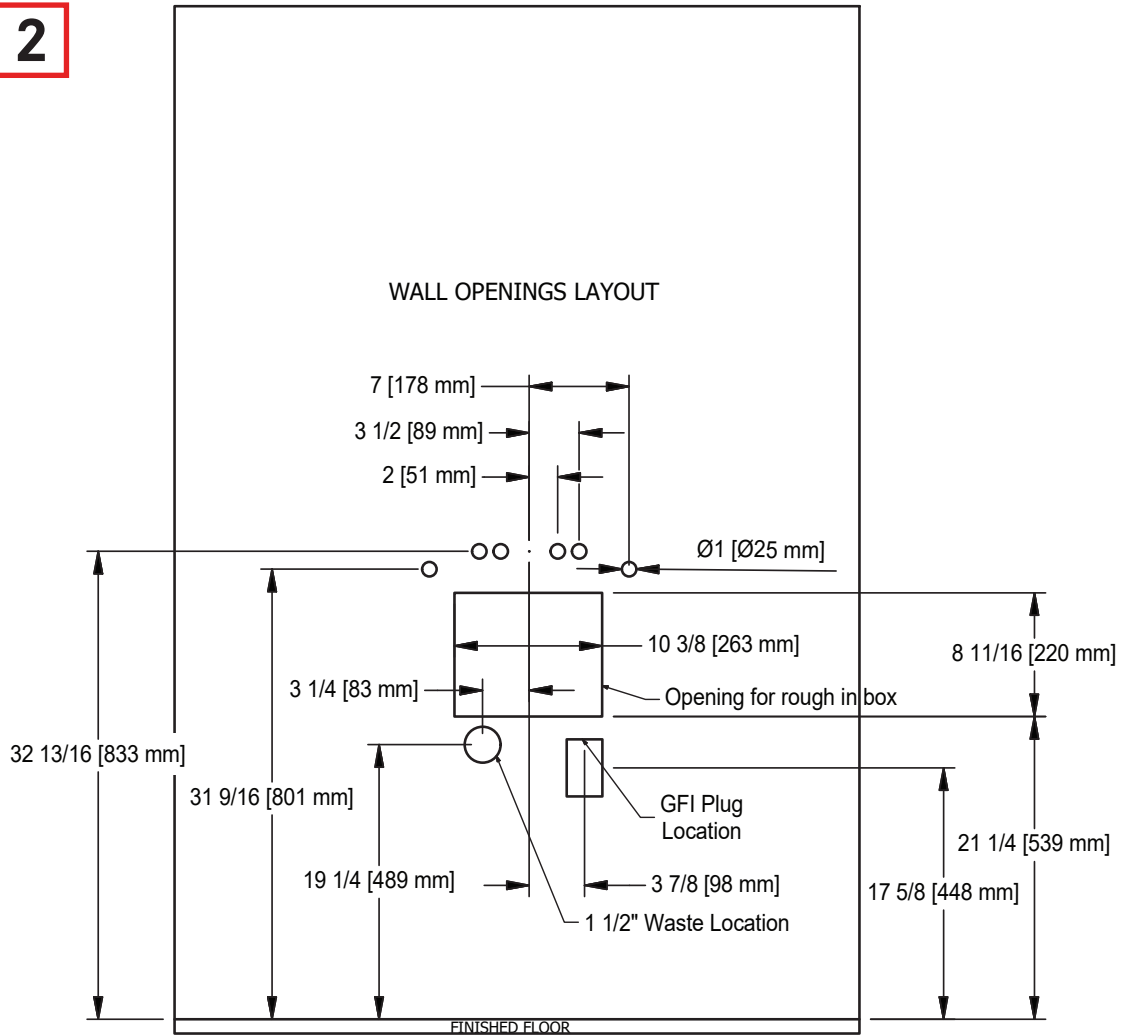

2

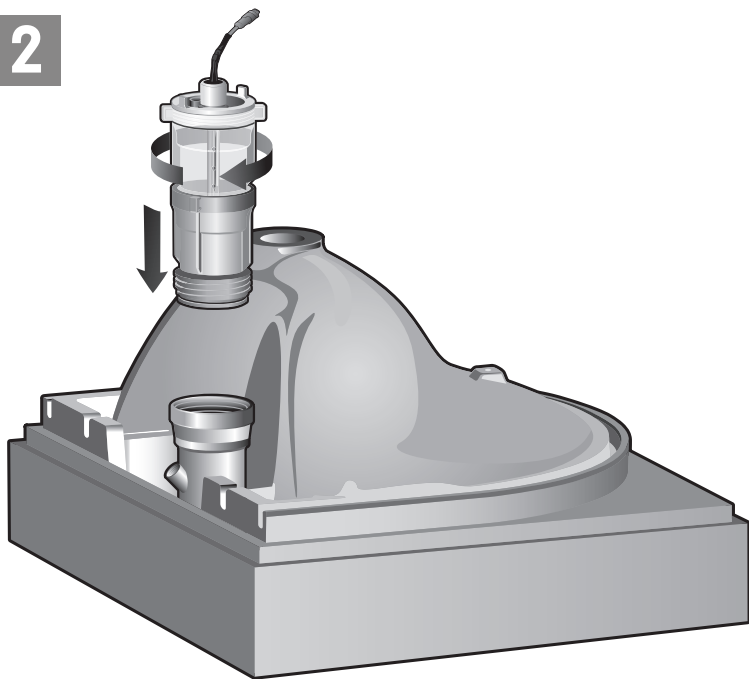

No tools

Hand tighten



3**MOUNT SINK**

Hang sink onto wall brackets and level the sink by eye. (Final levelling will take place after water flow is activated).

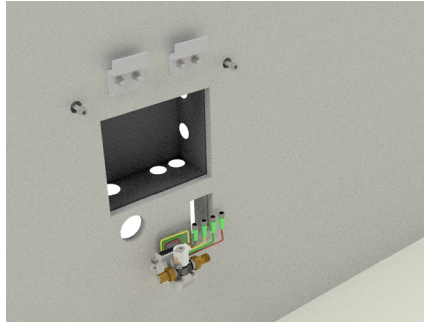
**4****INSTALL THE WASTE FITTING INTO THE SINK.**

- a. Disassemble the waste fitting.
- b. Slide the waste body and upper gasket into the sink hole.
- c. Thread the lock nut onto the body.
- d. Tighten into place.
- e. Insert the tailpiece into the tailpiece nut.
- f. Insert the tailpiece gasket into the tail
- g. Tighten the tailpiece assembly onto the waste body.
- h. Connect a standard p-trap (provided by others). The amount of space is limited to install the shroud. We recommend a 1 piece tubular trap without a cleanout plug on the bottom the trap.

5**ELECTRICAL CONNECTIONS**

Check local codes for compliance prior to making any electrical connections.

The water tight fittings have an alignment feature. Gently push the fittings together rotating until they engage. Little to no force should be required to do so. Once fitted together, lock together by threading the locking rings.

The connections are colour coded.

- a. Connect the blue banded wires together (electrolytic generator)
- b. Connect the yellow banded wires together (IR sensor)
- c. Connect the red banded wires together (water LED)
- d. Plug in the transformer to the black wire and plug into the GFI receptacle.
- e. Optional battery backup AT00-024 (white banded) cable

6 WATER CONNECTIONS

- Connect the supply line (pre-mixed or via thermostatic mixing valve) to the 1/2" MIP thread inlet (right side) of the solenoid valve.
- Take the supplied 3/8" tube and insert it into the output side (left) of the solenoid valve. Insert the other in the supplied shut off valve.
- Insert the other side into the bottom of the laminar flow chamber.
- If using a thermostatic mixing valve (Franke MEDI-MIX sold separately), recommended temperature is 27-35°C (80-95 F) (Hot or warmer water is both harsher on the user's skin and secondly, as water temperature increases, it loses its ability to dissolve ozone which can cause reductions in sanitization performance.) When adjusting the thermostatic mixing valve, set to minimum and verify water temperature is within recommended range.

7 TESTING

- Ensure that all plumbing lines have been properly flushed. If lines are not properly flushed, it can clog the check stops in the mixing valve and/or clog the strainer in the input side of the solenoid valve. This can result in low water flow.
- Please note, the output side of the solenoid valve contains a pressure regulator. The water lines MUST be purged of all air prior to sink operation. Otherwise it can cause the water stream to spit out of the orifice causing water to spray outside the sink.
- With system flushed and pressurized, place your hand in front of the IR sensor inside the sink bowl. You will hear the solenoid valve open and water will begin to run.
- Holding your hand in front of the sensor, you will see ...
 - water entering the clear laminar flow chamber,
 - the LED will be illuminated (seen from the spout), and
 - the electrolytic generator will be active. You will also see bubbles coming from the electrolytic generator into the water.
- If you have high pressure conditions, the shut off valve can be used to slightly reduce the stream length. Adjust as necessary so that the water targets this range when running. Cycle the sink multiple times until consistent.
- Hold your hand in the target area to make sure water triggers. Depending on local lighting conditions, sensor sensitivity may need to be adjusted. This can be done using the wireless handheld programmer AC01-005.



AC01-005

If any of the above is not functional, double check that the connections are colour-matched and that the connection is made properly.

Normal operation is as follows:

- IR sensor will see a users hand.
- This will trigger the water flow, LED and the electrolytic generator will turn on.
- When the user removes their hands to lather, the water flow will turn off however the electrolytic generator will stay on for 20 seconds (unless programmed otherwise). The electrolytic generator is self programming based on local water conductivity. If conductivity is in normal range of 75-350 TDS, the LED will cycle in intensity. If the conductivity is too high, the LED will blink quickly. If the conductivity is too low, the LED will slowly blink. After the 20 seconds the water flow will trigger by itself for 3 seconds. This is done to help signal the user of the 20 second minimum lather time and also for a subsequent wash rinse of the sink. After the 3 second post wash occurs, the electrolytic generator will begin a purge cycle. Once again the LED will pulse in intensity as the water in the electrolytic chamber is being charged with oxidants. When this cycle is complete, the LED will turn off.

Once the sink is operating properly, final leveling may occur. Ensure that the water stream hits the center of the water dispersion rib that runs along the sink bowl front to back.

When this is achieved, tighten down wall bracket hardware and secure lower mounting holes with either the supplied hardware included with the IWC2104 wall carrier (or appropriate hardware if installing onto a braced wall).

At this point the perimeter of the sink can be sealed to the wall using caulking.

8 INSTALL THE SHROUD.

The shroud upper flange will slide into the recess channel under the sink. To secure the shroud in place, there are two mounting screw locations.



9 INSTALL REMOVABLE USE AND CARE STICKER.

We recommend posting the included removable hand washing instruction sticker on wall above sink, to communicate to the users how the sink functions and its intended use for hand washing only.



10

PROBLEM	POSSIBLE CAUSES
Sink will not run (LED activates but no water will flow).w	1. Blocked dirt strainers on mixing valve or inlet side of solenoid valve. 2. PCB board and solenoid valve: Check cable connections
Sink will not run (no LED or water flow when triggered).	1. Check power power (confirm LED is visible on power supply). 2. IR sensor is not functioning, check cable connections.
Water stream is not seen running.	Check cable connection to LED (Red).
electrolytic generator is not seen running.	1. Check cable connection 2. Ensure water is not distilled or R/O filtered / TDS < 50.
Water output is too high.	1. Adjust shut off valve installed in 3/8" line. 2. Faulty flow control regulator found in brass output port of the solenoid valve.
Water output is too low.	1. Faulty flow control regulator found in brass output port of the solenoid valve. 2. Obstruction on dirt strainer in inlet of solenoid valve or, if equipped, in TMV.
Water is not shutting off.	Water droplets or debris or hard water marks/stains are covering oval sensor window. Ensure this area is clean and free of debris or stains.
Water flows without activating sensor.	Water will automatically trigger 20 seconds after last use for a post-wash rinse. Water will also automatically trigger during trap disinfection cycles. These are intentional activations programmed for optimum hygiene.
LED blinking slowly (1x per second)	Electrolytic generator undercurrent fault. Check cable connections and water conductivity.
LED blinking quickly (2x per second)	Electrolytic generator overcurrent fault. 1. Water conductivity too fast, contact customer service 2. Mechanical damage to the electrolytic generator (anode and cathode touching). 3. Foreign object shorting out electrolytic generator.

11

USE AND CARE

The Medi-flo sink is made from Miranit®; a mineral composite with a premium gel coat. Avoid the use of strong acids, paint removing compounds and abrasives.

12

SPARE PARTS

1 Solenoid Valve
#AC17-104



2 Mixing Valve
#MEDI-MIX



3 Solenoid & Control Board Assembly
#AT00-181

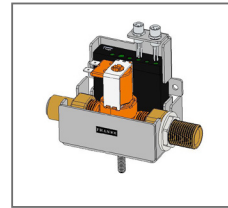

4 Programmable Control Board
#AT00-190

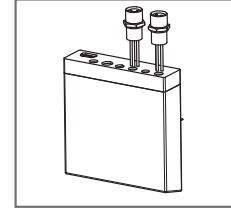

13

OZONE GENERATOR TECHNICAL INFORMATION

The electrolytic generator within Medi-flo not only generates a variety of oxidants which all work together to help destroy harmful bacteria and viruses. The amount of mixed oxidants produced by the system is a function of the water conductivity (total dissolved salts - TDS) and water composition such as hardness, alkalinity, PH, iron, manganese, etc.) and the flow rate (or length of time the generator is running with or without water flow during the use or during trap purge disinfection cycles). For optimum performance we recommend installation in areas with conductivity between 75-350TDS. If below 75TDS, the ozone generator will still function down to as low as TDS of 50; however oxidant output may be reduced to under 0.5ppm (measured by chemical reagent DPD tests). TDS can be measured using a small TDS reader, your local water or pool supply store or by sending in a sample of 250ml minimum to our customer service. Tests such as ORP and Indigo may not give valid readings due to hydrogen interference, temperature, water composition and PH. Subtract the reading obtained from straight tap water to remove any reading from chlorine.

The default operation of the electrolytic generator is to run a charge cycle after every use. Target canister charge is 2.0ppm of mixed oxidants. During this charge cycle, you will see the LED pulse in intensity (this can be adjusted or turned off with the handheld programmer AC01-005). Typical output is approximately as follows:

@ 50 TDS =45min
 @150 TDS =17min
 @200 TDS =12 min
 @250 TDS =7 min
 @300 TDS =4 min
 @350 TDS =3 min.

During a hand wash cycle, when the initial signal is received to wash hands, the user typically wets their hands and then commences lathering. While they pull away their hands to lather, the water flow will stop but we keep the oxidant generator running for 20 seconds to build up concentration in the chamber to be available for the rinse cycle. Alternatively, after 20 seconds of last use the water flow will automatically come on for an additional 3 seconds. The intention is that 20 seconds after last use the sink will dispense a small amount of water for a post rinse clean of the sink and trap to remove any remaining soap residue. Water softeners will increase TDS and are recommended if your conductivity is low; however, reverse osmosis or de-ionized water are not compatible with Medi-flo.

(continued)

WARRANTY: If inspection the product confirms that it is defective in materials or workmanship, Franke Kindred Canada Ltd. will, at their choosing, repair or exchange the product during the following periods:

Sink, waste fitting and shroud - 2 years

Water controls and electronics - 1 year

NOTE: In the event of a limited warranty claim, proof of purchase date will be required.

Franke Kindred Canada Limited

1000 Franke Kindred Road

Midland, ON L4R 4K9

Tel 1.855.446.5663

Fax 1.866.227.3050

Email: commercial-info.ca@franke.com

www.franke-commercial.com

